



Landtechnik
Agricultural engineering

RIV-Flanschschieber

RIV-flange gate valve



RIV-Gülleflanschschieber aus Messing

mit Edelstahlschrauben und 2 Dichtringen

RIV brass slurry flange gate valve

with stainless steel screws and 2 gaskets

Lochabstand hole distance (mm)	Baulänge overall length (mm)	Best.-Nr. order-no.	Euro Stück piece
150	4"	97	8001 100000
150	5"	93	8001 125000
150	6"	93	8001 150000
180	8"	112	8001 200000

Ersatzteile für obige Gülleflanschschieber:

Spare parts for above mentioned slurry flange gate valve:

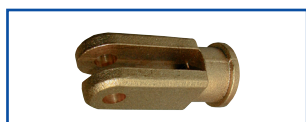

Gabelkopf

fork head

4"-6"	8001 100001
8"	8001 200001



Stopfbuchsmutter

gland nut

4"-6"	8001 100002
8"	8001 200002



Stopfbuchsdichtung

gland gasket

4"-6"	8001 100003
8"	8001 200003



Inbusschraube aus V2a

Allen screw consist of V2A

4"-8"	8001 100004
-------	-------------



Oberteil

top part

5"	8001 125005
6"	8001 150005



Hubstange

lifting rod

4"	8001 100006
5"	8001 125006
6"	8001 150006
8"	8001 200006



Keil

wedge

Stärke/strength mm		
19 x 8	4"	8001 100007
22 x 8	5"	8001 125007
25 x 8	6"	8001 150007
41 x 17	8"	8001 200007

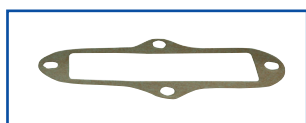

Dichtung

gasket

4"	8001 100008
5"	8001 125008
6"	8001 150008

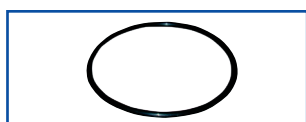

O-Ring

o-ring

4"-6"	8001 100010
8"	8001 200010

RIV brass slurry thread gate valve
with stainless steel screws

RIV-Güllegewindeschieber aus Messing
mit Edelstahlschrauben

	Baulänge overall length (mm)	Best.-Nr. order-no.	Euro Stück piece
4"	68	8002 100000	
5"	78	8002 125000	
6"	82	8002 150000	



Ersatzteile für obige Güllegewindeschieber:
Spare parts for above mentioned slurry thread gate valve:

fork head	Gabelkopf	
4"-6"	8001 100001	
gland nut	Stopfbuchsmutter	
4"-6"	8001 100002	
gland gasket	Stopfbuchsdichtung	
4"-6"	8001 100003	
Allen screw consist of V2A	Inbusschraube aus V2a	
4"-6"	8001 100004	
top part	Oberteil	
5"	8001 125005	
6"	8001 150005	
lifting rod	Hubstange	
4"	8001 100006	
5"	8001 125006	
6"	8001 150006	
wedge	Keil	
Stärke/strength mm		
19 x 8	4"	8001 100007
22 x 8	5"	8001 125007
25 x 8	6"	8001 150007
gasket	Dichtung	
4"	8001 100008	
5"	8001 125008	
6"	8001 150008	

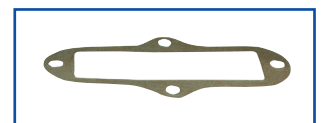
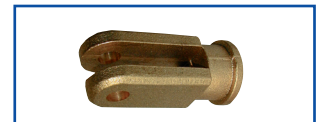

MZ-Flanschschieber

MZ-flange gate valve



MZ-Gülleflanschschieber aus Messing

mit Edelstahlschrauben
und 2 Dichtringen

MZ brass slurry flange gate valve

with stainless steel screws
and 2 gaskets

Lochabstand hole distance (mm)	Baulänge overall length (mm)	Best.-Nr. order-no.	Euro Stück piece
150	4"	90	8006 100000
150	5"	90	8006 125000
150	6"	90	8006 150000
180	8"	112	8006 200000

Ersatzteile für obige Gülleflanschschieber:

Spare parts for above mentioned slurry flange gate valve:

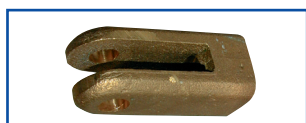

Gabelkopf

fork head

4"-8"	8006 100001
-------	-------------



Stopfbuchsmutter

gland nut

4"-6"	8006 100002
8"	8006 200002

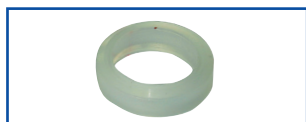

Stopfbuchsdichtung

gland gasket

4"-6"	8006 100003
8"	8006 200003



Inbusschraube aus V2a

Allen screw consist of V2A

4"-8"	8001 100004
-------	-------------



Oberteil

top part

4"	8006 100005
5"	8006 125005
6"	8006 150005
8"	8006 200005



Hubstange

lifting rod

6"	8006 150006
8"	8006 200006



Keil

wedge

Stärke/strength mm		
20 x 8	4"	8006 100007
23 x 8	5"	8006 125007
26 x 8,5	6"	8006 150007
42 x 19	8"	8006 200007

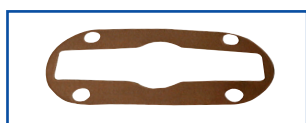

Dichtung

gasket

4"	8006 100008
5"	8006 125008
6"	8006 150008
8"	8006 200008

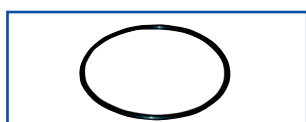

O-Ring

o-ring

4"-6"	8001 100010
8"	8001 200010

MZ brass slurry thread gate valve
with stainless steel screws

MZ-Güllegewindeschieber aus Messing
mit Edelstahlschrauben

	Baulänge overall length (mm)	Best.-Nr. order-no.	Euro Stück piece
4"	70	8007 100000	
5"	72	8007 125000	
6"	82	8007 150000	



Ersatzteile für obige Güllegewindeschieber:
Spare parts for above mentioned slurry thread gate valve:

fork head	Gabelkopf	
4"-6"	8006 100001	
gland nut	Stopfbuchsmutter	
4"-6"	8006 100002	
gland gasket	Stopfbuchsdichtung	
4"-6"	8006 100003	
Allen screw consist of V2A	Inbusschraube aus V2a	
4"-6"	8001 100004	
top part	Oberteil	
4"	8007 100005	
6"	8007 150005	
lifting rod	Hubstange	
5"	8006 125006	
6"	8006 150006	
wedge	Keil	
Stärke/strength mm		
29 x 18	4"	8007 100007
33 x 18	5"	8007 125007
35 x 18	6"	8007 150007
gasket	Dichtung	
4"	8007 100008	
5"	8007 125008	
6"	8007 150008	

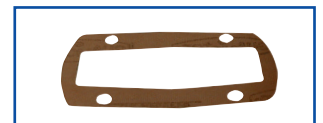
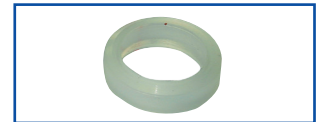



RIV-Gülleschieber aus Messing

einerseits Flansch, andererseits Innengewinde mit Edelstahlschrauben

RIV brass slurry gate valve

one side flange other side female thread with stainless steel screws

	Baulänge overall length (mm)	Best.-Nr. order-no.	Euro Stück piece
4"	79	8003 10000	
5"	87	8003 125000	
6"	88	8003 150000	



MZ-Gülleflasschieber aus Messing

ohne Spindel mit Edelstahlschrauben

MZ brass slurry flange gate valve

without spindle with stainless steel screws

6"	90	8005 150000	
----	----	-------------	--



MZ-Gülleflasschieber

mit gebohrter Oese für Hebelgarnitur

MZ slurry flange gate valve

with bored eyelet for lever set

6"	90	8006 150001	
8"	90	8006 200001	



MZ-Gülleflasschieber aus Messing

mit großem Oberteil und 2 Dichtringen

MZ brass slurry flange gate valve

with big top section and 2 gaskets

6"	110	8004 150150	
----	-----	-------------	--



MZ-Klingenschieber aus Messing mit Kolbenstange

Schieberkeil und Schrauben aus Edelstahl und 2 Dichtringen

Brass MZ blade gate valve with piston rod

stainless steel valve wedge and screws and 2 gaskets

Lochabstand/ hole distance (mm)				
150	6"	68	8008 150000	
195	8"	90	8008 200000	



Anschluss-Flanschstück für 6" Klingenschieber

mit 6" Quadrat-Flansch 70 mm lang

Adapter flange part for 6" blade gate valve

with 6" square flange 70 mm long

150	6"	8022 170150	
-----	----	-------------	--

Simple lever set

galvanized

Einfache Hebelgarnitur

verzinkt

	Best.-Nr. order-no.	Euro Stück piece
4"	8010 100000	
5"	8010 125000	
6"	8010 150000	
8"	8010 200000	



Lever set lockable

galvanized

Hebelgarnitur abschließbar

verzinkt

4"	8011 100000	
6"	8011 150000	
8"	8011 200000	



for MZ brass slurry flange gate valve with big top section
order no. 8004 150150

für MZ-Gülleflanschschieber mit großem Oberteil
Best.-Nr. 8004 150150

6"	8014 150000	
----	-------------	--

Lever set, heavy model

galvanized, without valve

Hebelgarnitur, schwere Ausführung

verzinkt, ohne Schieber

4"-6"	8012 150001	
8"	8012 200000	



Lever set, heavy model

galvanized

Hebelgarnitur, schwere Ausführung

verzinkt

4"-6"	8012 150000	
-------	-------------	--



Guide lubrication bush

with lubrication nipple

Führungs-Schmierbuchse

mit Schmiernippel

5"-6"	8013 150000	
8"	8013 200000	



Pipe nipple

for weld on
black - with male thread
overall length 100 mm
thread length 25 mm

Rohrrippel

zum Anschweißen
schwarz - mit Außengewinde
Gesamtlänge 100 mm
Gewindelänge 25 mm

2"	8020 050000	
2 1/2"	8020 063000	
3"	8020 075000	
4"	8020 100000	
5"	8020 125000	
6"	8020 150000	
8"	8020 200000	



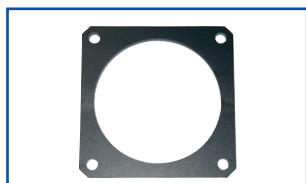

Stahlflansch

passend für Gülleflanschschieber
schwarz

Steel flange

suitable for slurry gate flange valve
black

A.-Ø outer-Ø (mm)	Lochabstand hole distance (mm)		Best.-Nr. order-no.	Euro Stück piece
150 x 150	120 - Eisele	4"	8021 100120	
180 x 180	150	4"	8021 100150	
180 x 180	150	5"	8021 125150	
180 x 180	150	6"	8021 150150	
200 x 200	150	6"	8021 170150	
230 x 230	180	8"	8021 200180	



Edelstahl-Flansch V2A

Stainless steel flange V2A

180 x 180	150	6"	8026 150150	
-----------	-----	----	-------------	--



Rund-Flansch

zur Befestigung der PVC-Bundbuchse
am Flanschschieber, verzinkt

Round flange

for fit on the PVC bending socket
on flange gate valve, galvanized

d (mm)				
110		4"	8022 110000	
140		5"	8022 140000	
160		6"	8022 160000	
200		8"	8022 200000	



Rund-Flansch V2A

zur Befestigung der PVC-Bundbuchse

Round flange V2A

for fit on the PVC bending socket

160		6"	8026 160000	
200		8"	8026 200001	



Stahlflansch

mit angeschweißtem Rohrnippel, verzinkt

Steel flange

with welded on pipe nipple, galvanized

180 x 180	150	4"	8023 100000	
180 x 180	150	5"	8023 125000	
180 x 180	150	6"	8023 150000	
230 x 230	180	8"	8023 200000	

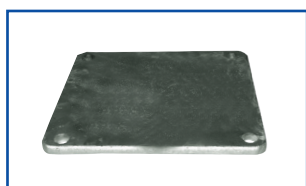

Stahl-Blind-Flansch

verzinkt

Steel blind flange

galvanized

180 x 180	150	4"	8024 100000	
180 x 180	150	5"	8024 100000	
180 x 180	150	6"	8024 100000	
230 x 230	180	8"	8024 200000	

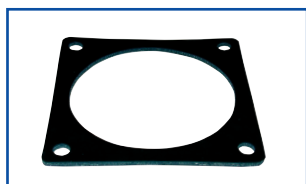

Gummi-Flanschdichtung

Rubber flange gasket

150 x 150	120 - Eisele	4"	8025 100120	
180 x 180	150	4"-6"	8025 100150	
230 x 230	180	8"	8025 200180	



Gummi-Kompensator

Typ ZKB mit DIN Flansch PN 10

Rubber compensator

type ZKB with DIN flange PN 10

100		4"	8028 100100	
125		5"	8028 125125	
150		6"	8028 150150	
200		8"	8028 200200	
300		12"	8028 300300	

Hydraulic cylinder

with stainless steel piston rod
single acting with gas pressure cylinder
with male thread, galvanized
for RIV and MZ slurry gate valves 4"-5"-6"
with female thread in top part M 30 x 2
Working pressure: 150 bar

Hydraulikzylinder

mit VA Kolbenstange
einfachwirkend mit Gasdruckzylinder
mit Außengewinde, galvanisch verzinkt
für RIV- und MZ-Güleschieber 4"-5"-6"
mit Innengewinde im Oberteil M 30 x 2
Betriebsdruck: 150 bar

	Kolbenstange piston rod VA/ss mm	Best.-Nr. order-no.	Euro Stück piece
4"	20	8050 100000	
5"	20	8050 125000	
6"	20	8050 150000	

with female thread in top part M 30 x 2

mit IG im Oberteil M 30 x 2

8"	22	8050 200000	
----	----	-------------	--

Remove the gland gasket in the top part of the valve,
during assembling the hydraulic cylinder!

Bei der Montage des Zylinders muß die Stopfbuchsichtung im
Oberteil des Schiebers entfernt werden.

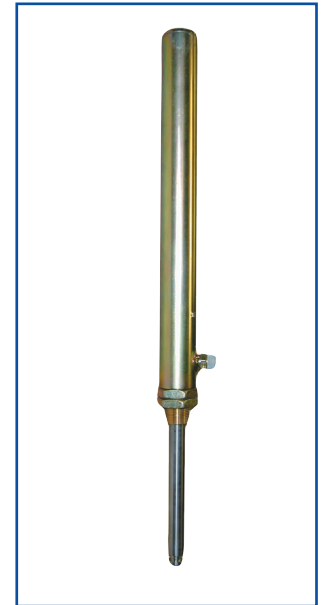

Spare parts for hydraulic cylinder with piston rod 14 mm

adapter

4"-6"	8050 100001
-------	-------------

Ersatzteile für Hydraulik-Zylinder mit Kolbenstange 14 mm

Adapter

Pneumatic cylinder MZ

double acting
7-10 bar pilot pressure

6"	8051 150000
8"	8051 200000

MZ-Pneumatic-Zylinder

doppelwirkend
7-10 bar Steuerdruck



Hydraulikschläuche und -kupplungen

Hydraulic hoses and couplings



Hydraulikschlauch DN 10/1 SN

komplett eingebunden
beidseitig Überwurfmutter
und Dichtkegel DKL M 18 x 1,5
ohne Kupplungsrippel
Betriebsdruck: 180 bar
Berstdruck: 720 bar

Hydraulic hose DN 10/1 SN

complete engaged
both sides union nut
and cone packing DKL M 18 x 1,5
without coupling nipple
working pressure: 180 bar
bursting pressure: 720 bar

	Best.-Nr. order-no.	Euro Stück piece
1,0 m	8060 010010	
2,0 m	8060 010020	
2,5 m	8060 010025	
4,0 m	8060 010040	
5,0 m	8060 010050	
6,0 m	8060 010060	
7,0 m	8060 010070	
7,5 m	8060 010075	
8,0 m	8060 010080	
9,0 m	8060 010090	
10,0 m	8060 010100	



Hydraulikschlauch DN 10/2 SN

komplett eingebunden
beidseitig Überwurfmutter
und Dichtkegel DKL M 18 x 1,5
ohne Kupplungsrippel
Betriebsdruck: 330 bar
Berstdruck: 1330 bar

Hydraulic hose DN 10/2 SN

complete engaged
both sides union nut
and cone packing DKL M 18 x 1,5
without coupling nipple
working pressure: 330 bar
bursting pressure: 1330 bar

500 mm	8061 010005	
600 mm	8061 010006	
800 mm	8061 010008	
1000 mm	8061 010010	
1200 mm	8061 010012	



Schnellverschluss-Kupplungsstecker

Quick release coupling plug

DN 10 L	M 18 x 1,5 AG	8063 010000
DN 13 L	M 22 x 1,5 AG	8063 013000



Schnellverschluss-Kupplungsstecker

mit Schottverschraubung

Quick release coupling plug

with stiffening screw connection

DN 10 L	M 18 x 1,5 AG	8064 010000
---------	---------------	-------------



Schnellverschluss-Kupplungsmuffe

Quick release coupling socket

DN 10 L	M 18 x 1,5 AG	8065 010000
DN 13 L	M 22 x 1,5 AG	8065 013000

Quick release coupling socket

with stiffening screw connection

Schnellverschluss-Kupplungsmuffe

mit Schottverschraubung

		Best.-Nr. order-no.	Euro Stück piece
DN 10 L	M 18 x 1,5 AG/MT	8066 010000	
DN 13 L	M 22 x 1,5 AG/MT	8066 013000	



Sealing set

O-ring and support ring

Dichtungssatz

O-Ring und Stützring

für Kupplungsmuffe/ for coupling socket	8067 000000
--	-------------



Screw coupling plug

with stiffening screw connection

Schraub-Kupplungsstecker

mit Schottverschraubung

DN 13 L	M 22 x 1,5 AG/MT	8069 013000
---------	------------------	-------------



Dust cap

Staubkappe

f. Schnellverschluss-Kupplungsstecker/ for quick release coupling plug	8073 000000
f. Schraub-Kupplungsstecker/ for screw coupling plug	8073 000001

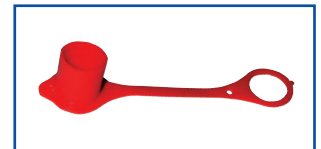

Dust plug

Staubstecker

f. Schnellverschluss-Kupplungsmuffe/ for quick release coupling socket	8073 000002
---	-------------

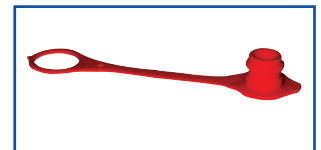

Block ball valve

Blockkugelhahn

NW	Gewinde/thread	BD/wp bar	
10	M 18 x 1,5 AG/MT	500	8074 010018
13	M 22 x 1,5 AG/MT	500	8074 013022
1/2"	1/2" AG/AG - MT/MT	350	8074 013013
1/2"	IG/FT	350	8074 013000
3/4"	3/4" AG/AG - MT/MT	350	8074 019019
3/4"	IG/FT	350	8074 019000
1"	1" AG/AG - MT/MT	350	8074 025025
1"	IG/FT	350	8074 025000

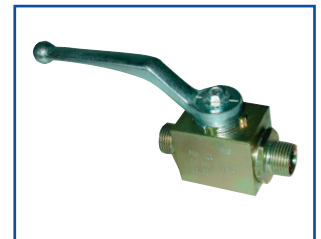

Block three-way ball valve

Blockkugel-Dreiwegehahn

10	M 18 x 1,5 AG/MT	400	8075 010000
13	M 22 x 1,5 AG/MT	350	8075 013000

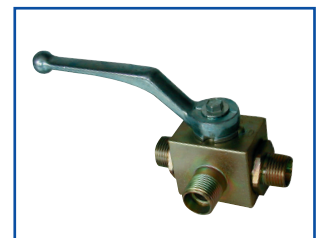

Zubehör für den Fasswagen

Accessories for slurry tankers

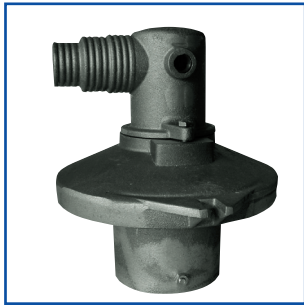

Haubendomdeckel aus Aluminium

passend für Dom 290 mm Ø
bestehend aus: Haube, Domdeckel, Domdeckeldichtung
sowie seitlich eingegossenem Anschluss für
Vakuummanometer 1/2". Haube mit Dreistufenanschluss
60, 75 und 80 mm Ø. (Der Anschluss 80 mm Ø wird durch
Abschneiden des Stutzens 75 mm Ø erreicht.)

Aluminium capped dome cover

suitable for dome 290 mm Ø
consisting of: cap, dome cover, dome cover gasket
and lateral cast-in connection for vacuum manometer
1/2" cap with three-step connection 60, 75 and
80 mm Ø (connection 80 mm Ø is achieved by cutting
nozzle 75 mm Ø off)

	Best.-Nr. order-no.	Euro Stück piece
	8100 00000	
Oberteil/top part	8100 00001	
Unterteil/bottom part	8100 00002	

Zubehör für Haubendomdeckel:

Accessories for capped dome cover:

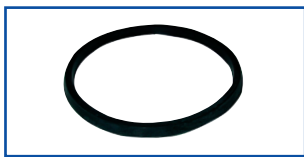

Domdeckeldichtung

dome cover gasket

290 mm Ø	8100 290000	
----------	-------------	--

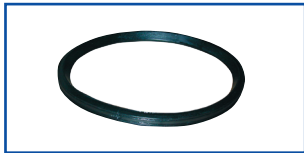

Dichtung zwischen Ober- und Unterteil

gasket between top and bottom part

	8100 000003	
--	-------------	--



Gummilippe für Schwimmerkugel

rubber lip for float ball

100 mm Ø	8100 100000	
----------	-------------	--

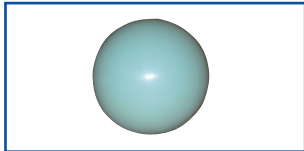

Schwimmerkugel - PE

PE - float ball

100 mm Ø	8214 100004	
----------	-------------	--



Augenschraube galvanisch verzinkt

eyebolt galvanized

M 16 x 120	8100 016120	
M 20 x 100	8100 020100	



Ringmutter galvanisch verzinkt zur Befestigung des Haubendomdeckels

ring nut galvanized for fix capped dome cover

M 16	8100 016000	
------	-------------	--



Reduzierstück aus Messing für Vakuummanometer 1/4"

brass reducing nipple for vacuum manometer 1/4"

1/2" AG/MT x 1/4" IG/FT	8100 013006	
-------------------------	-------------	--

Vacuum manometer

indicating range: -1/+1,5 bar
connection 1/4" at 9 o'clock
Ø 63 mm, suitable for capped dome cover

rote Markierung bei red marking at		Best.-Nr. order-no.	Euro Stück piece
-0,5 und +0,5 bar	1/4"	8110 006005	
-0,5 und +1,0 bar	1/4"	8110 006010	

Glycerine manometer

indicating range: -1/+1,5 bar
connection 1/4" at 9 o'clock
Ø 63 mm, suitable for capped dome cover

-0,5 und +1,0 bar	1/4"	8111 006010	
-------------------	------	-------------	--

Vacuum manometer

indicating range: -1/+1,5 bar
connection 1/4" below
Ø 63 mm

-0,5 und +0,5 bar	1/4"	8112 006005	
-0,5 und +1,0 bar	1/4"	8112 006010	

Glycerine-vacuum manometer

indicating range: -1/+1,5 bar
connection 1/4" below
Ø 63 mm

-0,5 und +0,5 bar	1/4"	8113 006005	
-0,5 und +1,0 bar	1/4"	8113 006010	

Vacuum manometer

indicating range: -1/+1,5 bar
connection 1/2" below
Ø 80 mm

-0,5 und +0,5 bar	1/2"	8114 013005	
-0,5 und +1,0 bar	1/2"	8114 013010	

Brass safety valve

with hose connection and stainless steel spring, non-tested part

0,5 bar	1 1/4"	8200 032005	
0,5 bar	1 1/2"	8200 038005	
0,5 bar	2"	8200 050005	
1,0 bar	1 1/4"	8200 032010	
1,0 bar	1 1/2"	8200 038010	
1,0 bar	2"	8200 050010	

Vacuum underpressure valve

with cover
adjustable -0,3 up to -0,8

	1 1/2"	8201 038000	
--	--------	-------------	--

Vakuu-Manometer

Anzeigenbereich: -1/+1,5 bar
Anschluss 1/4" bei 9.00 Uhr
Ø 63 mm, passend für Haubendomdeckel



Glyzerin-Vakuu-Manometer

Anzeigenbereich: -1/+1,5 bar
Anschluss 1/4" bei 9.00 Uhr
Ø 63 mm, passend für Haubendomdeckel

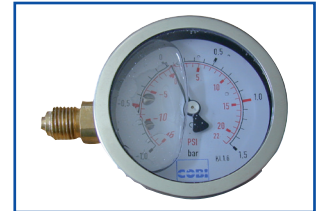

Vakuu-Manometer

Anzeigenbereich: -1/+1,5 bar
Anschluss 1/4" unten
Ø 63 mm



Glyzerin-Vakuu-Manometer

Anzeigenbereich: -1/+1,5 bar
Anschluss 1/4" unten
Ø 63 mm



Vakuu-Manometer

Anzeigenbereich: -1/+1,5 bar
Anschluss 1/2" unten
Ø 80 mm



Messing-Sicherheitsventil

mit Schlauchanschluss und rostfreier Stahlfeder
nicht bauteilgeprüft



Vakuu-Unterdruckventil

mit Haube
einstellbar -0,3 bis -0,8



Zubehör für den Fasswagen

Accessories for slurry tankers



Proportional-Sicherheitsventil

mit Federbelastung und Anlüftevorrichtung
offene Ausführung, bauteilgeprüft
* mit Ablasschutzhaube für Pressluft

Proportional safety valve

with spring loaded and lifting device
non-enclosed model, tested part
* with blowing protection cap for compressed air

		Best.-Nr. order-no.	Euro Stück piece
0,5 bar	1 1/2"	8202 038005	
0,5 bar	2"	8202 050005	
0,9 bar	1 1/2"	8202 038009	
1,0 bar	1 1/4"	8202 032010	
1,0 bar	1 1/2"	8202 038010	
1,0 bar	2"	8202 050010	
2,0 bar	1 1/2"	8202 038020	
2,0 bar *	1 1/2"	8202 038000	
2,5 bar *	1 1/2"	8202 038025	



Schauglas aus Plexiglas

mit Dichtring

Plexiglass sight glass

with gasket

2" AG/MT	8203 050000
3" AG/MT	8203 075000



LM-Schauglasflansch TW 511

(3-teilig) mit Stehbolzen
DN 80 mit 3" AG

LM-sight glass flange TW 511

(3-part) with stay bolt
DN 80 with 3" mt

8204 075000



Schauglashalter 3" IG x 3" AG

Holder for sight glass 3" ft x 3" mt

8205 075000

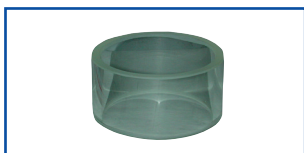

Ersatzglas für Schauglasflansch

DN 80

Spare glass for sight glass flange

DN 80

8204 075001

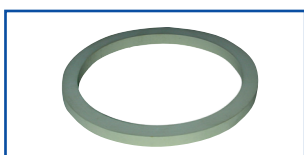

Dichtung für Schauglas

Gasket for sight glass

8204 075002



Anschweißstahlring

Steel ring for weld on

2" IG/FT	8203 050001
3" IG/FT	8203 075001



Füllstands-Schauglas

große, stabile Ausführung zum Einschweißen,
bestehend aus:
Einschweißstahlring 135 mm Ø mit Spannbügel
und MS-Rändelschraube, Alu-Druckplatte,
Schauglas 115 mm Ø und Gummi-Flachdichtung

Level sight glass

large, rugged model for weld-in consisting of:
weld-in steel ring 135 mm Ø with tension clip
and brass knurled screw, aluminium pressure plate,
slight glass 115 mm Ø and rubber flat gasket

	135 mm Ø	8206 135000
Ersatzglas/spare glass	115 mm Ø	8206 115001
Dichtung/gasket	115 mm Ø	8206 115002

Level indicator for weld-in

Füllstandsanzeiger zum Einschweißen

	Best.-Nr. order-no.	Euro Stück piece
kpl. mit Gestänge und Schwimmerkugel/ complete with lever system and float ball	8210 050000	
Gummimanschette lose/rubber boot loose	8210 050001	

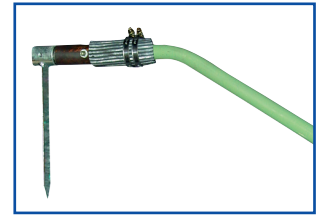

Overflow valve

with two balls and connection...

Überlaufventil

mit zwei Kugeln und Anschluss...

60 mm Ø	8211 060060
80 mm Ø	8211 080080



Aluminium connection elbow with brass union nut for overflow valve

Alu-Anschlussbogen mit MS-Überwurfmutter für Überlaufventil

60 mm Ø	8211 060001
---------	-------------

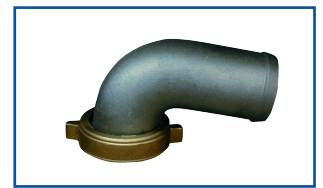

Double ball valve

with two balls, with lateral connection possibilities
for safety valve 1 1/2" and connection above 3/8"
for manometer

Doppelkugelventil

mit zwei Kugeln, mit Anschlussmöglichkeit seitlich für
Sicherheitsventil 1 1/2" und Anschluss oben 3/8" für
Manometer

60 mm Ø	8212 060000
Ersatzglas/spare glass	8212 000001
Ersatzdichtung/spare gasket	8212 000002



Plexiglass pipe

for level indicator
extruded in lengths of 2 m

Plexiglasrohr

für Füllstandsanzeiger
extrudiert in Längen von 2 mtr.

90 x 80 mm	8213 090080
100 x 90 mm	8213 100090

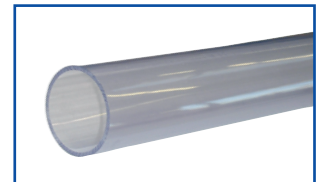

Black rubber float ball

Schwimmerkugel

Ø	Gewicht		
mm	weight	Material	
60	90	Gummi mit Korkkern/rubber with cork core	8214 060090
60	110	Gummi mit Holzkern/rubber with wooden core	8214 060110
70	100	Gummi mit Korkkern/rubber with cork core	8214 070100
70	140	PE hohl/PE hollow	8214 070140
70	190	Gummi massiv/rubber massive	8214 070190
80	160	Gummi mit Korkkern/rubber with cork core	8214 080160
80	210	Gummi mit Holzkern/rubber with wooden core	8214 080210
80	300	Gummi massiv/rubber massive	8214 080300
100	110	PE hohl/PE hollow	8214 100110
100	300	PE hohl/PE hollow	8214 100004
100	385	PP mit Holzkern/PP with wooden core	8214 100005
150	300	PE hohl mit Bohrung/PE hollow with bore	8214 150300



Rubber lip for float ball

Gummilippe für Schwimmerkugel

80 mm Ø	8215 080000
100 mm Ø	8100 100000



Zubehör für den Fasswagen

Accessories for slurry tankers



Syphon-Abscheider aus Aluminium

mit 1/4" Innengewinde für Vakuummanometer

Siphon separator consist of Aluminium

with 1/4" female thread for vacuum manometer

	Best.-Nr. order-no.	Euro Stück piece
60 mm Ø	8220 060000	



Syphon-Abscheider mit Kunststoffgehäuse

3,5 Liter Fassungsvermögen

Siphon separator with plastic casing

3,5 litre capacity

80 mm Ø	8221 080000	
---------	-------------	--



MZ-Syphon-Abscheider

mit Kunststoffgehäuse

MZ siphon separator

with plastic casing

60 mm Ø	8222 060000	
80 mm Ø	8222 080000	



Syphon-Abscheider aus Stahl

rostschutzlackiert mit 1" Ablasshahn und Schlauchanschluss sowie Schauglas 2"

Siphon separator consist of steel

anti-rust lacquered with 1" drain cock and hose connection and sight glass 2"

100 mm Ø	8223 100000	
----------	-------------	--

Ersatzteile für Syphon-Abscheider:

Plexiglas-Klarsichttasse

mit Gummi-Dichtung
bei Bestellung bitte Fabrikat angeben

Spare parts for siphon separators:

Plexiglass transparent cup

with rubber gasket
by ordering please note product



ohne Bohrung für RIV-AluAusführung/ without bore for RIV aluminium model	8229 000001	
für Stahlausführung (Schauglas 2")/ for steel model (sight glass 2")	8203 050000	
mit Bohrung für RIV-AluAusführung/ with bore for RIV aluminium model	8249 000003	
mit 3/4" IG und Blindstopfen für MZ/ with 3/4" female thread and blind plug for MZ	8229 000004	
mit 1/2" Gewinde für Moro/ with 1/2" thread for Moro	8229 000005	
mit Bajonettverschluss für MZ/ with bayonet lock for MZ	8229 000007	



für RIV-Kunststoffausführung/ for RIV plastic model	8229 000008	
--	-------------	--

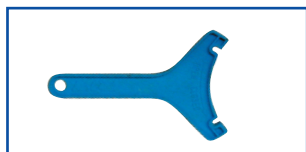

Montageschlüssel für Klarsichttasse RIV/ assembly key for sight glass RIV	8229 000030	
--	-------------	--



Schnellkupplungs-Stahlring

Quick release steel ring

	8229 000009	
--	-------------	--

Drain cock
with tension nut and sealing ring

Ablasshahn
mit Spannmutter und Dichtring

	Best.-Nr. order-no.	Euro Stück piece
1/2"	8229 000011	
3/8"	8229 000012	



Brass blind plug

Messing-Blindstopfen

für RIV-Syphonabscheider aus Alu for aluminium RIV siphon separator	1/4"	3372 006000
--	------	-------------



O-ring for transparent cup

O-Ring für Klarsichttasse

passend für Tasse zum Abscheider/ suitable for cup to separator		
RIV - Neue Ausführung/RIV - new model		8229 000013
RIV - Aluausführung/RIV - aluminium model		8229 000014
MZ/MZ		8229 000015
MORO/MORO		8229 000016
MZ - Kunststoffausführung/MZ - plastic model		8229 000018
MZ/MZ		8229 000029



Hose connection straight
flat sealing

Schlauchanschluss gerade
flachdichtend

für Syphonabscheider/ for siphon separator		
für RIV aus Alu/for RIV aluminium	60 mm	8229 000019
für MORO aus Alu/for MORO aluminium	50 mm	8229 000021



Brass union nut
for hose connection

MS-Überwurfmutter
für Schlauchanschluss

RIV/RIV	60 mm	8229 000023
---------	-------	-------------



Hose connection 90°

Schlauchanschluss 90°

für Syphonabscheider/ for siphon separator		
für MZ aus Messing/for MZ brass	60 mm	8229 000025



Italienisches Kupplungssystem

Italian couplings system



MT-Kupplung

mit Gummiring, zum Anschweißen
schwarz

Female coupling

with rubber ring, for weld on
black

NW	Best.-Nr. order-no.	Euro Stück piece
80	8300 080000	
100	8300 100000	
120	8300 120000	
150	8300 150000	
200	8300 200000	
250	8300 250000	



M-Kupplung

zum Anschweißen, schwarz

Male coupling

for weld on, black

80	8301 080000	
100	8301 100000	
120	8301 120000	
150	8301 150000	
200	8301 200000	
250	8301 250000	



MT-Kupplung mit Schlauchtülle

verzinkt

für Schlauch
for hose l.-Ø (mm)

Female coupling with hose nozzle

galvanized

80	75	8302 080075
100	50	8302 100050
100	100	8302 100100
100	110	8302 100110
120	50	8302 120050
120	100	8302 120100
120	110	8302 120110
120	120	8302 120120
120	125	8302 120125
120	133	8302 120133
150	50	8302 150050
150	100	8302 150100
150	110	8302 150110
150	120	8302 150120
150	125	8302 150125
150	133	8302 150133
150	150	8302 150150
150	159	8302 150159
200	200	8302 200200

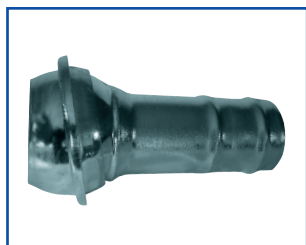

M-Kupplung mit Schlauchtülle

verzinkt

Male coupling with hose nozzle

galvanized

80	75	8303 080075
100	50	8303 100050
100	100	8303 100100
100	110	8303 100110
120	50	8303 120050
120	100	8303 120100
120	110	8303 120110
120	120	8303 120120
120	125	8303 120125
120	133	8303 120133
150	50	8303 150050
150	100	8303 150100
150	110	8303 150110
150	120	8303 150120
150	125	8303 150125
150	133	8303 150133
150	150	8303 150150
150	159	8303 150159
200	200	8303 200200

Female coupling with male thread

galvanized

NW	Best.-Nr. order-no.	Euro Stück piece
100 - 2 1/2"	8304 100063	
100 - 4"	8304 100100	
120 - 2 1/2"	8304 120063	
120 - 4"	8304 120100	
120 - 5"	8304 120125	
150 - 2 1/2"	8304 150063	
150 - 4"	8304 150100	
150 - 5"	8304 150125	
150 - 6"	8304 150150	

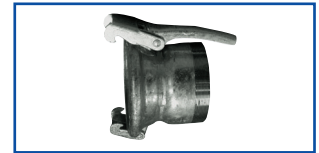

Male coupling with male thread

galvanized

100 - 2 1/2"	8305 100063
100 - 4"	8305 100100
120 - 2 1/2"	8305 120063
120 - 4"	8305 120100
120 - 5"	8305 120125
150 - 2 1/2"	8305 150063
150 - 4"	8305 150100
150 - 5"	8305 150125
150 - 6"	8305 150150



Female coupling

with bored 4-corner flange, galvanized

100 - 4"	8306 100100
120 - 5"	8306 120125
150 - 6"	8306 150150
200 - 8"	8306 200200



Male coupling

with bored 4-corner flange, galvanized

100 - 4"	8307 100100
120 - 5"	8307 120125
150 - 6"	8307 150150
200 - 8"	8307 200200



Bend 45°

with male and female coupling, galvanized

120	8308 120000
150	8308 150000

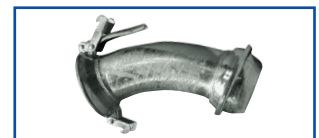

Bend 90°

with male and female thread, galvanized

100	8309 100000
120	8309 120000
150	8309 150000



End plug female coupling, galvanized

100	8311 100000
120	8311 120000
150	8311 150000



End plug male coupling, galvanized

100	8312 100000
120	8312 120000
150	8312 150000



Rubber ring for female coupling

80	8313 080000
100	8313 100000
120	8313 120000
150	8313 150000
200	8313 200000
250	8313 250000



MT-Kupplung mit Außengewinde

verzinkt

NW	Best.-Nr. order-no.	Euro Stück piece
100 - 2 1/2"	8304 100063	
100 - 4"	8304 100100	
120 - 2 1/2"	8304 120063	
120 - 4"	8304 120100	
120 - 5"	8304 120125	
150 - 2 1/2"	8304 150063	
150 - 4"	8304 150100	
150 - 5"	8304 150125	
150 - 6"	8304 150150	

M-Kupplung mit Außengewinde

verzinkt

100 - 2 1/2"	8305 100063
100 - 4"	8305 100100
120 - 2 1/2"	8305 120063
120 - 4"	8305 120100
120 - 5"	8305 120125
150 - 2 1/2"	8305 150063
150 - 4"	8305 150100
150 - 5"	8305 150125
150 - 6"	8305 150150

MT-Kupplung

mit gebohrtem 4-Eckflansch, verzinkt

100 - 4"	8306 100100
120 - 5"	8306 120125
150 - 6"	8306 150150
200 - 8"	8306 200200

M-Kupplung

mit gebohrtem 4-Eckflansch, verzinkt

100 - 4"	8307 100100
120 - 5"	8307 120125
150 - 6"	8307 150150
200 - 8"	8307 200200

Bogen 45° mit M- und MT-Kupplung

verzinkt

120	8308 120000
150	8308 150000

Bogen 90° mit M- und MT-Kupplung

verzinkt

100	8309 100000
120	8309 120000
150	8309 150000

Endstopfen MT-Kupplung, verzinkt

100	8311 100000
120	8311 120000
150	8311 150000

Endstopfen M-Kupplung, verzinkt

100	8312 100000
120	8312 120000
150	8312 150000

Gummiring für MT-Kupplung

80	8313 080000
100	8313 100000
120	8313 120000
150	8313 150000
200	8313 200000
250	8313 250000

Saugrohre

Suction pipes



Verlängerungsrohr aus Stahl

mit MT- und M-Kupplung
verzinkt

Steel suction pipe

with female and male coupling
galvanized

Ø mm	Best.-Nr. order-no. 2 m	Euro Stück piece	Best.-Nr. order-no. 3 m	Euro Stück piece	Best.-Nr. order-no. 4 m	Euro Stück piece
100	8330 100002		8330 100003			



Saugrohr aus Stahl

mit M-Kupplung
verzinkt

Steel suction pipe

with male coupling
galvanized

	2 m	3 m	4 m
100		8331 100003	
150	8331 150002	8331 150003	8331 150004



Saugrohr aus Stahl

mit Handgriff
verzinkt

Steel suction pipe

with handle
galvanized

	2 m	3 m	4 m
100	8333 100002	8333 100003	
110		8333 110003	
120		8333 120003	
125	8333 125002	8333 125003	
133	8333 133002	8333 133003	
150	8333 150002	8333 150003	8333 150004
159	8333 159002	8333 159003	



Saugrohr aus Stahl mit Bogen 45°

mit Handgriff und Schlauchtülle
verzinkt

Steel suction pipe with bend 45°

with handle and hose nozzle
galvanized

	3 m	4 m
125	8334 125003	
133	8334 133003	8334 133004
150	8334 150003	8334 150004



Rührlanzenrohr

verzinkt

Agitating lance pipe

galvanized

Ø mm	4 m
50	8335 050004

Perfect distributor

with rubber nozzle, tension jaw clamp and perfect baffle plate, galvanized with male coupling Italian system

NW	Best.-Nr. order-no.	Euro Stück piece
120	8380 120000	
150	8380 150000	

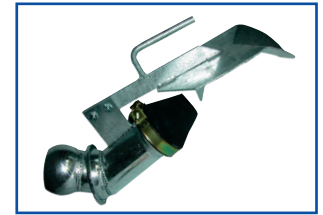

Perfect distributor

galvanized, with female coupling Italian system

120	8381 120000	
150	8381 150000	

Perfekt-Verteiler

verzinkt, mit MT-Kupplung italienisches System



Rear outlet

with detachable rubber nozzle 100 mm and baffle plate, galvanized with male coupling Italian system

100	8384 100000	
120	8384 120000	
150	8384 150000	

Hintere Ausbringung

mit abnehmbarer Gummidüse 100 mm und Prallteller, verzinkt mit M-Kupplung italienisches System

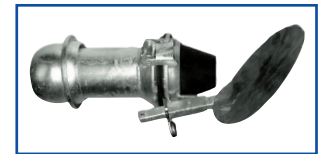

Rear outlet

with detachable rubber nozzle 100 mm and baffle plate, galvanized with female coupling Italian system

100	8385 100000	
120	8385 120000	
150	8385 150000	

Hintere Ausbringung

mit abnehmbarer Gummidüse 100 mm und Prallteller, verzinkt mit MT-Kupplung italienisches System



Connection couplings

Female coupling

with 4-corner flange, galvanized

100 - 4"	8306 100100	
120 - 5"	8306 120125	
150 - 6"	8306 150150	
200 - 8"	8306 200200	

Anschlusskupplungen

MT-Kupplung

mit 4-Eckflansch, verzinkt



Male coupling

with 4-corner flange, galvanized

100 - 4"	8307 100100	
120 - 5"	8307 120125	
150 - 6"	8307 150150	
200 - 8"	8307 200200	

M-Kupplung

mit 4-Eckflansch, verzinkt



Female coupling

with male thread, galvanized

100 - 4"	8304 100100	
120 - 5"	8304 120125	
150 - 6"	8304 150150	

MT-Kupplung

mit Außengewinde, verzinkt



Male coupling

with male thread, galvanized

100 - 4"	8305 100100	
120 - 5"	8305 120125	
150 - 6"	8305 150150	

M-Kupplung

mit Außengewinde, verzinkt





Seitenverteiler und Hintere Ausbringung

verzinkt
Bogen 90° mit Halterung für Breitverteiler, abnehmbare Gummidüse 100 mm, Stahlring mit Halterung und Federstecker für: Verteilerstift (extra bestellen), Flügelrad (extra bestellen), oder Prallteller (extra bestellen)

Side distributor and rear outlet

galvanized
bend 90° with holder for wide distributor detachable rubber nozzle 100 mm, steel ring and holder for spring clip for distributor pin (extra to order)

NW		Best.-Nr. order-no.	Euro Stück piece
120	mit MT-Kupplung/with female coupling	8386 120000	
150	mit MT-Kupplung/with female coupling	8386 150000	
120	mit M-Kupplung/with male coupling	8387 120000	
150	mit M-Kupplung/with male coupling	8387 150000	

Zubehör für Seitenverteiler und Hintere Ausbringung:

Accessories for side distributor and rear outlet:

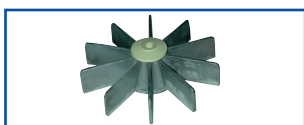

Flügelrad aus Alu 160 mm Ø

Aluminium impeller 160 mm Ø

8388 000003



Flügelrad-Halterung

mit gelochtem Vierkantrrohr

Impeller holder

with perforated square pipe

8388 000004



Flügelrad-Halterung

mit gelochtem Flacheisen

Impeller holder

with sectional perforated flat iron

8388 000005



Prallteller 240 mm

mit gelochtem Vierkantrrohr

Baffle plate 240 mm

with perforated square pipe

8388 000006

Zubehör für Verteiler und Ausbringung:

Accessories for distributor and outlet:



Stahldüse 50 mm

verzinkt mit M-Kupplung

Steel nozzle 50 mm

galvanized with male coupling

120

8388 120008

150

8388 150009



Stahldüse 50 mm

verzinkt mit MT-Kupplung

Steel nozzle 50 mm

galvanized with female coupling

120

8388 120011

150

8388 150012



Prallteller für Stahldüsen

mit angeschweißten, gelochtem Flacheisen
verzinkt

Baffle plate for steel nozzles

with welded on, sectional perforated flat iron
galvanized

8388 000013

Rubber nozzle

suitable for:

NW		Best.-Nr. order-no.	Euro Stück piece
120	für Perfekt-Verteiler 4"/for perfect distributors 4"	8389 120100	
133	für Perfekt-Verteiler 5"/for perfect distributors 5"	8389 133125	
160	für Perfekt-Verteiler 6"/for perfect distributors 6"	8389 160150	



Rubber nozzle with collar

for female coupling 100 mm

Bohrung/bore 45 mm	8388 000014
--------------------	-------------

Gummidüse mit Rand

für MT-Kupplung 100 mm



Baffle plate, 240 mm

mit gelochtem Vierkanthohr/with perforated square pipe	8388 000006
mit Flacheisen/with flat iron	8388 000015

Prallteller, 240 mm



Steel ring

with square pipe end part for rubber nozzle, galvanized

	8388 000016
--	-------------

Stahlring

mit Vierkanthohrendstück für Gummidüse, verzinkt

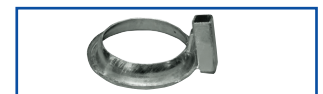

Double spring clip

6 mm, galvanized

	8388 000017
--	-------------

Doppelfeder-Vorstecker

6 mm, verzinkt



Perfect baffle plate

with sectional perforated flat iron, galvanized

	8388 000018
--	-------------

Perfekt-Prallteller

mit gelochtem Flacheisen, verzinkt

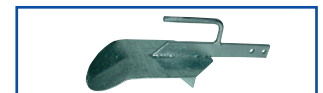

Perfect baffle plate with

wide spray protection with sectional perforated flat iron, galvanized

	8388 000019
--	-------------

Perfekt-Prallteller mit

Breitspritzschutz mit gelochtem Flacheisen, verzinkt



Accessories for slurry tanks:

Rubber hollow chamber packing profile
universal, 30 mm wide, 35 mm high

	8390 000000
--	-------------

Zubehör für Güllefässer:

Hohlkammer-Dichtprofil aus Gummi
universal, 30 mm breit, 35 mm hoch



Hook screw

for rear panel, complete with ring nut and grommet

M 20 x 155 mm	8392 022155
---------------	-------------

Hakenschaube

für Rückwand, komplett mit Ringmutter und U-Scheibe



Eccentric closure

for rear panel, consisting of: hook screw, bolt nut and clamping closure

M 20 x 140 mm	8393 000000
---------------	-------------

Excenterverschluss

für Rückwand, bestehend aus: Hakenschaube, Bolzenmutter und Spannverschluss



Split lance

Square pipe 80/20 with bend 90°, 2 1/2" male thread galvanized, without fire-brigade coupling

2 m lang/long	8394 000000
---------------	-------------

Spaltenlanze

Rechteckrohr 80/20 mit Bogen 90°, 2 1/2" AG verzinkt, ohne Feuerwehrcupplung



Aluminium fixed coupling

Storz 75-B - 2 1/2" female thread

	2101 075063
--	-------------

Alu-Festkupplung

Storz 75-B - 2 1/2" IG

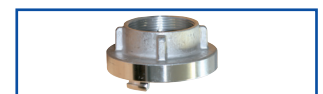

Agitating lance pipe

4 m long, galvanized

50 mm Ø	8335 050004
---------	-------------

Rührlanzenrohr

4 m lang, verzinkt



Feuerwehr-Übergangsstücke

Fire-brigade adapter parts

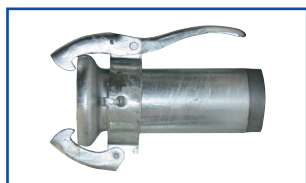

M-Teil mit Außengewinde

verzinkt

Female coupling with male thread

galvanized

NW		Best.-Nr. order-no.	Euro Stück piece
89	2 1/2"	2420 089063	
108	2 1/2"	2420 108063	
133	2 1/2"	2420 133063	
159	2 1/2"	2420 159063	
108	4"	2420 108100	
133	4"	2420 133100	
159	4"	2420 159100	



V-Teil mit Außengewinde

verzinkt

Male coupling with male thread

galvanized

89	2 1/2"	2421 089063	
108	2 1/2"	2421 108063	
133	2 1/2"	2421 133063	
159	2 1/2"	2421 159063	
108	4"	2421 108100	
133	4"	2421 133100	
159	4"	2421 159100	



MT-Kupplung mit Außengewinde

verzinkt

Female coupling with male thread

galvanized

100	2 1/2"	8304 100063	
120	2 1/2"	8304 120063	
150	2 1/2"	8304 150063	
100	4"	8304 100100	
120	4"	8304 120100	
150	4"	8304 150100	



M-Kupplung mit Außengewinde

verzinkt

Male coupling with male thread

galvanized

100	2 1/2"	8305 100063	
120	2 1/2"	8305 120063	
150	2 1/2"	8305 150063	
100	4"	8305 100100	
120	4"	8305 120100	
150	4"	8305 150100	



Alu-Festkupplung mit Innengewinde

Aluminium fixed coupling with female thread

	IG/FT	KA/KD (mm)	
52-C	2 1/2"	66	2101 052063
75-B	2 1/2"	89	2101 075063
110-A	4"	133	2101 110100

Female coupling
with rubber ring, black

MT-Kupplung
mit Gummiring, schwarz

NW	Best.-Nr. order-no.	Euro Stück piece
150	8410 150000	



Male coupling
black

M-Kupplung
schwarz

150	8411 150000	
-----	-------------	--



Female coupling
with hose nozzle
galvanized

MT-Kupplung
mit Schlauchtülle
verzinkt

NW	für Schlauch for hose I-Ø (mm)	Best.-Nr. order-no.	Euro Stück piece
150	150	8412 150150	
150	159	8412 150159	



Male coupling
with hose nozzle
galvanized

M-Kupplung
mit Schlauchtülle
verzinkt

150	150	8413 150150	
-----	-----	-------------	--

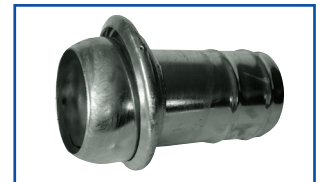

Male coupling
with male thread
galvanized

M-Kupplung
mit Außengewinde
verzinkt

150 - 6"	8415 150150	
----------	-------------	--



Female coupling
with 4-corner flange
galvanized

MT-Kupplung
mit 4-Eckflansch
verzinkt

150 - 6"	8416 150150	
----------	-------------	--



Male coupling
with 4-corner flange
galvanized

M-Kupplung
mit 4-Eckflansch
verzinkt

150 - 6"	8417 150150	
----------	-------------	--



Rubber ring

Gummiring

150	8418 150000	
-----	-------------	--





Perfekt-Verteiler

mit Gummidüse, Mikalor-Spannbackenschelle und Perfekt-Prallteller, verzinkt mit MT-Kupplung System Bazzoli-Siegerle

Perfect distributor

with rubber nozzle, Mikalor-tension jaw clamp and perfect baffle plate, galvanized with female coupling system Bazzoli-Siegerle

NW

Best.-Nr.

Euro

order-no.

Stück
piece

150

8510 150000



Perfekt-Verteiler mit Breitspritzschutz

verzinkt mit MT-Kupplung System Bazzoli-Siegerle

Perfect distributor with

wide spray protection
galvanized with female coupling system Bazzoli-Siegerle

150

8511 150000



Perfekt-Verteiler

verzinkt mit V-Teil System Perrot

Perfect distributor

galvanized with male coupling system Perrot

159

mit Zarge/with border

8412 159000



Perfekt-Verteiler

verzinkt mit M-Teil System Perrot

Perfect distributor

galvanized with female coupling system Perrot

108

8413 108000

133

8413 133000

159

mit Zarge/with border

8413 159000

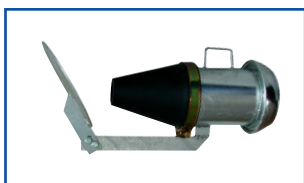

Hintere-Ausbringung mit Gummidüse und Prallteller

verzinkt mit V-Teil System Perrot

Rear outlet with rubber nozzle and baffle plate

galvanized with male thread system Perrot

133

8416 133000

159

mit Zarge/with border

8416 159000

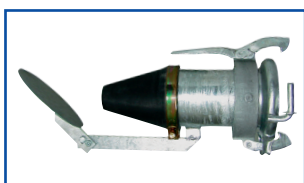

Hintere-Ausbringung mit Gummidüse und Prallteller

verzinkt mit M-Teil System Perrot

Rear outlet with rubber nozzle and baffle plate

galvanized with female thread system Perrot

108

8417 108000

133

8417 133000

159

mit Zarge/with border

8417 159000

Male coupling with 4-corner flange
galvanized, 150 mm long

NW	Best.-Nr. order-no.	Euro Stück piece
108 - 4"	2426 108100	
133 - 5"	2426 133125	
159 - 6"	2426 159150	
159 - 8"	2426 159200	



Female coupling with 4-corner flange
galvanized, 360 mm long

108 - 4"	2425 108100	
133 - 5"	2425 133125	
159 - 6" mit Zargenführung/with centric device groove	2428 159150	



Male coupling with male thread
galvanized

108 - 4"	2421 108100	
133 - 5"	2421 133125	
159 - 6"	2421 159150	



Female coupling with male thread
galvanized

108 - 4"	2420 108100	
133 - 5"	2420 133125	
159 - 6"	2420 159150	

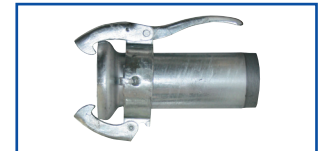

Perfect baffle plate
with sectional perforated flat iron, galvanized

8388 000018

Perfekt-Prallteller
mit gelochtem Flacheisen, verzinkt

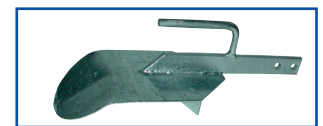

Perfect baffle plate
with wide spray protection

8388 000019

Perfekt-Prallteller
mit Breitspritzschutz



Baffle plate 240 mm Ø
with perforated square pipe for rear outlet

8388 000015

Prallteller 240 mm Ø
mit gelochtem Flacheisen für Hintere Ausbringung

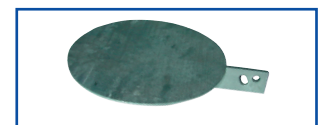

Accessories for side and wide distributor:

Zubehör für Seiten- und Breitverteiler:

Aluminium impeller 160 mm Ø

8388 000003

Flügelrad aus Alu 160 mm

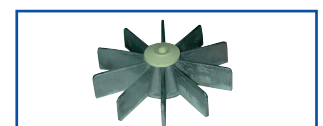

Impeller holder
with sectional perforated flat iron

8388 000005

Flügelrad-Halterung
mit gelochtem Flacheisen



Docking bell
elastic with mounting clamp
for lateral or rearward docking
without coupling necessity

für Rohr/for pipe		
159 mm	150-6"	8433 150000
220 mm	200-8"	8433 200000
273 mm	250-10"	8433 250000

Andock-Trichter
Elastisch mit Befestigungsschelle
zum seitlichen oder rückwärtigen
Andocken ohne zu kuppeln



Saug-Schnellkuppler

Suction quick coupler



Saugschlauchschnellkuppler

mit MT-Becherteil und Anschlussflansch
sowie mit Entlüftungshahn 1/2" verzinkt
italienisches System

Suction quick coupler

with female bucket part and connection flange
with vent nipple 1/2" galvanized
Italian system

NW

Best.-Nr.

Euro

order-no.

Stück
piece

MT-150 x 6"

8430 150150



Saugschlauchschnellkuppler

mit angeschweißtem Kardanbecher und Flansch,
verzinkt, schwere Ausführung
V2a-Gewindespindel M 12 bei 6"
V2a-Gewindespindel M 16 bei 8"
System Perrot

Suction quick coupler

with welded on cardan bucket and flange,
galvanized, heavy model
V2A - threaded spindle M 12 at 6"
V2A - threaded spindle M 16 at 8"
system Perrot

159-6" mit Entlüftungshahn 3/4" /with vent nipple 3/4" 8432 159150

216-8" mit Entlüftungshahn 1" /with vent nipple 1" 8432 216200

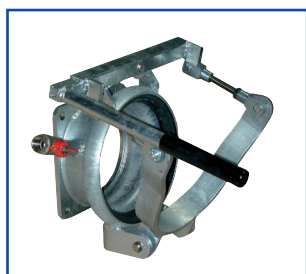

Saugschlauchschnellkuppler

mit angeschweißtem Kardanbecher und Flansch,
verzinkt, kurze Ausführung, Länge 165 mm
V2a-Gewindespindel M 10 bei 6"
V2a-Gewindespindel M 16 bei 8"
System Perrot

Suction quick coupler

with welded on cardan bucket and flange,
galvanized, short model, length 165 mm
V2A - threaded spindle M 10 at 6"
V2A - threaded spindle M 16 at 8"
system Perrot

159-6" mit Entlüftungshahn 1/2" /with vent nipple 1/2" 8436 159150

216-8" mit Entlüftungshahn 3/4" /with vent nipple 3/4" 8436 216200

4-corner flange with pipe connection for PVC pressure pipes
galvanized

NW	Rohrstutzen pipe connection (mm)	Best.-Nr. order-no.	Euro Stück piece
100-4"	110	8440 100110	
125-5"	140	8440 125140	
150-6"	160	8440 150160	

4-Eckflansch mit Rohrstutzen für PVC-Druckrohr
verzinkt



Wall joint connection 300 mm long
both sides 4-corner flange
galvanized

6"	8442 150000
----	-------------

Maueranschlusssutzen 300 mm lang
beidseitig 4-Eckflansch
verzinkt



Wall joint connection with male thread
plug-in possibility for sewer pipe, galvanized

DN 150 = A.-Ø 160 mm, 3,6 mm Wand/wall	6"	8443 150160
---	----	-------------

Maueranschlusssutzen mit Außengewinde
Einsteckmöglichkeit für Kanalrohr, verzinkt



Adapter 300 mm long
both sides 4-corner flange and lateral connection with 2" male thread, galvanized

6"	8445 150000
8"	8445 200000

Zwischenstück 300 mm lang
beiderseits 4-Eckflansch und seitlichem Stutzen mit 2" AG
verzinkt



Adapter 300 mm long
one side 4-corner flange, other side male coupling and lateral connection with 2" male thread
galvanized

159-6"	8446 159150
216-8"	8446 216200

Zwischenstück 300 mm lang
einerseits 4-Eckflansch, andererseits V-Teil und seitlichem Stutzen mit 2" AG
verzinkt



Adapter, galvanized
one side male coupling, other side 4-corner flange and flange gate valve with lever set, outlet to the bottom ball valve 2" with lever system
complete assembled

159-6"	8447 159150
216-8"	8447 216200

Zwischenstück, verzinkt
einerseits V-Teil, andererseits 4-Eckflansch und Flanschschieber mit Hebelgarnitur, Abgang nach unten Kugelhahn 2" mit Hebelgestänge
kpl. montiert



Anschlüsse für Behältersysteme

Junctions for vat systems



Verteilerstück 300 mm lang

2 x 4-Eckflansch 6",
1 x V-Teil 159 mm, verzinkt

Distributor fitting 300 mm long

2 x 4-corner flange 6",
1 x male coupling 159 mm, galvanized

Best.-Nr. order-no.	Euro Stück piece
------------------------	------------------------

8449 159150

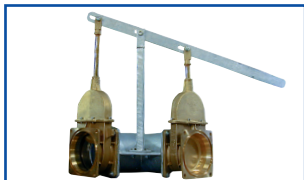

Verteilerstück

3 x 4-Eckflanschanschluss mit doppelwirkender Hebelbetätigung für Gülleflanschschieber, verzinkt ohne Flanschschieber

Distributor fitting

3 x 4-corner flange connection with double-acting lever operation for slurry flange gate valve, galvanized without flange gate valve

6"	8450 150000
8"	8450 200200



Verteilerstück

3 x 4-Eckflanschanschluss auf V-Teil mit doppelwirkender Hebelbetätigung für Gülleflanschschieber, verzinkt

Distributor fitting

2 x 4-corner flange connection and 1 male coupling with double-acting lever operation for slurry flange gate valve, galvanized

8"	8450 200000
----	-------------



T-Stück

3 x 4-Eckflanschanschluss,
250 mm lang, verzinkt

T-fitting

3 x 4-corner flange connection,
250 mm long, galvanized

Abgang/ outlet		
6"	6"	8451 150000
8"	6"	8451 200150
8"	8"	8451 200000



Zwei- und Dreiwege-Flanschhahn - MZ

aus GG mit Messing-Küken, Messing-Bedienungshebel eingebauten Schmiernippel und Dichtungen DN 200 ohne Messing-Bedienungshebel

Two- and three-way flange cock MZ

cast iron GG with brass rotary plug valve, brass operating lever housed lubricator nipple and gaskets DN 200 without brass operating lever

Lochabstand/ hole distance (mm)	DN	
150	100	8454 100150
150	125	8454 125150
150	150	8454 150150
180	200	8454 200180

Ersatzteile für Zwei-Dreiwege-Flanschhahn - MZ:

Spare parts for two-three-way flange cock - MZ:

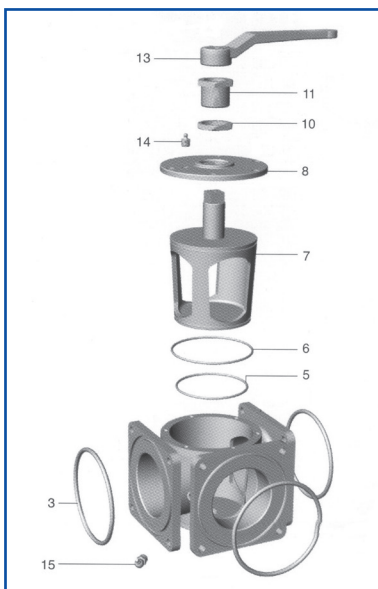

Pos.	Bezeichnung description	Best.-Nr. order-no.	Euro Stück piece
3	O-Ring/o-ring	8450 000001	
5	O-Ring 4"/o-ring 4"	8450 000002	
5	O-Ring 5"/o-ring 5"	8450 000003	
5	O-Ring 6"/o-ring 6"	8450 000004	
6	O-Ring 6"/o-ring 6"	8450 000005	
7	Küken 6"/rotary plug valve 6"	8450 000006	
8	Deckel 6"/top part 6"	8450 000007	
10	Mutter M 46 x 2/nut M 46 x 2	8450 000008	
11	Umlaufmutter M 46 x 2/rotation nut M 46 x 2	8450 000009	
13	Hebel/lever	8450 000010	
14	Schmiernippel 1/4"/lubricator nipple 1/4"	8450 000011	
15	Schmiernippel 1/4" 45°/lubricator nipple 1/4" 45°	8450 000012	

Flange adapter 4-corner flange

NW	Best.-Nr. order-no.	Euro Stück piece
6" - 8"	150 - 200	8022 150200

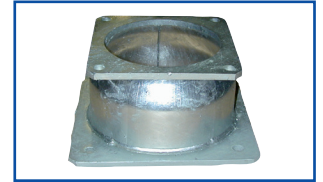

Pipe clamp

adjustable as telescopic model, galvanized
210 - 330 mm

150	8026 150000
200	8026 200000

Rohrschelle

verstellbar als Teleskopausführung, verzinkt
210 - 330 mm

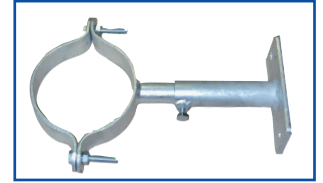

4-corner flange

black, as counter flange

Außen-Ø/ outer-Ø (mm)	Lochabstand/ hole distance		
180 x 180	150	4"	8021 100150
180 x 180	150	5"	8021 125150
180 x 180	150	6"	8021 150150

4-Eckflansch

schwarz, als Gegenflansch

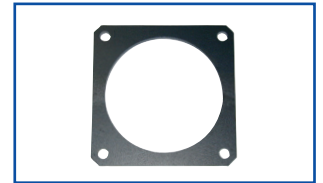

Flange gasket

rubber

180 x 180	150	4"-6"	8025 100150
-----------	-----	-------	-------------

Flanschdichtung

aus Gummi

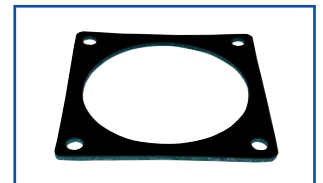

GG rotating joint

working pressure: max. 10 bar
housing test pressure: 16 bar

Ø	4"	6"	8"	10"
Baulänge (mm)/overall length (mm)	127	127	127	127
A.-Ø Flansch (mm)/outer-Ø flange (mm)	250	290	350	400
Lochabstand (mm)/hole distance (mm)	220	260	320	360
Anzahl Löcher/quantity holes	6	6	6	6
Loch-Ø (mm)/hole-Ø (mm)	15	15	15	15
Gewicht (kg)/weight (kg)	16	20,8	26,5	45,5

Drehgelenke aus GG

Betriebsdruck: max. 10 bar
Gehäuseprüfdruck: 16 bar



DN	Best.-Nr. order-no.	Euro Stück piece
100 - 4"	8455 100000	
150 - 6"	8455 150000	
200 - 8"	8455 200000	
250 - 10"	8455 250000	

Loose counter flange for rotating joints

100 - 4"	8456 100000
150 - 6"	8456 150000
200 - 8"	8456 200000

Lose Gegenflansche für Drehgelenke



Absperrschieber

Turn-off valves

Absperrschieber aus Gusseisen GG nach DIN 1691

Cast iron GG turn-off valves according to DIN 1691



Handschieber für Kunststoffrohr-Anschluss

Hand valve
for plastic pipe connection

DN	Best.-Nr. order-no.	Euro Stück piece
125	8470 125000	
150	8470 150000	
200	8470 200000	



Schnellschluss-Schieber Zugstange aus NIROSTA-Stahl max. Betriebsdruck 1,5 bar für Ton- und Kunststoffrohr-Anschluss

Sleeve quick valve
NIROSTA steel tie rod
max. working pressure 1,5 bar
usable for clay and plastic pipe connection

250	8472 250000	
300	8472 300000	



Spindelschieber mit Handrad Spindel aus NIROSTA-Stahl für Ton- und Kunststoffrohr-Anschluss max. Betriebsdruck 2,0 bar

Spindle valve with hand wheel
NIROSTA steel spindle
usable for clay and plastic pipe connection
max. working pressure 2,0 bar

250	8473 250000	
300	8473 300000	
400	8473 400000	



Keiflachschieber DIN 3325 2C F4, aus GGG 40, Flanschen PN 10 gebohrt, mit Handrad Spindel aus NIROSTA-Stahl mit weichdichtendem Keil, wartungsfrei EKB beschichtet

Slide flat valve
DIN 3325 2C F4, GGG 40,
flanges PN 10 bored, with hand wheel
NIROSTA steel spindle with soft sealing wedge,
maintenance-free, EKB coated

100	8475 100000	
125	8475 125000	
150	8475 150000	
200	8475 200000	
300	8475 300000	

Vorschweißflansch DIN 2633 PN 16

Welded-on flange DIN 2633 PN 16



Lochkreis/ bolt circle (mm)	Bund-Außen/ collar outside (mm)		
180 x 8	108	100	2300 100000
210 x 8	133	125	2300 125000
240 x 8	159	150	2300 150000
295 x 12	219,7	200	2300 200000
295 x 8	216 PN 10	200	2300 295000

Dichtung für Vorschweißflansch

Gasket for welded-on flange



100	2305 100000	
125	2305 125000	
150	2305 150000	
200	2305 200000	

Glycerine manometer

for field sprayer plants
housing: stainless steel
connection: brass
housing-Ø: 63 mm

Glyzerin-Manometer

für Feldspritzanlagen
Gehäuse: Edelstahl
Anschluss: Messing
Gehäuse-Ø: 63 mm

Anzeigebereich indicating range (bar)	Einteilung division (bar)	Anschluss connection	Best.-Nr. order-no.	Euro Stück piece
0-5-25	1/10	1/4" unten/below	8120 006025	
0-5-25	1/20	1/4" hinten/rear	8121 006025	
0-10-60	2/10	1/4" unten/below	8120 006060	



Glycerine manometer

stainless steel

for field sprayer plants, liquid fertilizer proof
housing: stainless steel
connection: stainless steel
housing-Ø: 63 mm

Glyzerin-Manometer aus Edelstahl

für Feldspritzanlagen, flüssigdüngerfest
Gehäuse: Edelstahl
Anschluss: Edelstahl
Gehäuse-Ø: 63 mm

0-5-25	1/10	1/4" unten/below	8122 006025
0-5-25	1/10	1/4" hinten/rear	8123 006025
0-10-25	1/10	1/4" unten/below	8122 006060



Manometer

housing-Ø: 63 mm

Manometer

Gehäuse-Ø: 63 mm

0 - 6	1/4" unten/below	8125 006006
0 - 10	1/4" unten/below	8125 006010
0 - 16	1/4" unten/below	8125 006016
0 - 40	1/4" unten/below	8125 006040
0 - 16	1/4" hinten/rear	8126 006016



Manometer

housing-Ø: 100 mm

Manometer

Gehäuse-Ø: 100 mm

0 - 4	1/2" unten/below	8127 013004
0 - 16	1/2" unten/below	8127 013016



Glycerine manometer

housing-Ø: 63 mm

Glyzerin-Manometer

Gehäuse-Ø: 63 mm

0 - 6	1/4" unten/below	8128 006006
0 - 10	1/4" unten/below	8128 006010
0 - 16	1/4" unten/below	8128 006016
0 - 25	1/4" unten/below	8128 006025
0 - 250	1/4" unten/below	8128 006250
0 - 250	1/4" hinten/rear	8129 006250



Manometer

Manometer



Vakuummeter

Gehäuse-Ø: 63 mm

Vacuum meter

housing-Ø: 63 mm

Anzeigenbereich indicating range (bar)	Anschluss connection	Best.-Nr. order-no.	Euro Stück piece
-1 - 0	1/4" unten/below	8115 006000	

Vakuummeter

Gehäuse-Ø: 100 mm

Vacuum meter

housing-Ø: 100 mm

-1 - 0	1/2" unten/below	8116 013000	
--------	------------------	-------------	--



Glyzerin-Vakuummeter

Gehäuse-Ø: 63 mm

Glycerine vacuum meter

housing-Ø: 63 mm

-1 - 0	1/4" unten/below	8117 006000	
--------	------------------	-------------	--

Vakuu-Manometer

rote Marke bei -0,5 und +0,5 bar

Gehäuse-Ø: 63 mm

Vacuum manometer

red marking at -0,5 and +0,5 bar

housing-Ø: 63 mm

-1 - +1,5	1/4" unten/below	8112 006005	
-1 - +1,5	1/4" 9 Uhr/9 o'clock	8110 006005	



rote Marke bei -0,5 und +0,5 bar

Gehäuse-Ø: 80 mm

red marking at -0,5 and +0,5 bar

housing-Ø: 80 mm

-1 - +1,5	1/2" unten/below	8114 013005	
-----------	------------------	-------------	--



rote Marke bei -0,5 und +1,0 bar

Gehäuse-Ø: 63 mm

red marking at -0,5 and +1,0 bar

housing-Ø: 63 mm

-1 - +1,5	1/4" unten/below	8112 006010	
-1 - +1,5	1/4" 9 Uhr/9 o'clock	8110 006010	

rote Marke bei -0,5 und +1,0 bar

Gehäuse-Ø: 80 mm

red marking at -0,5 and +1,0 bar

housing-Ø: 80 mm

-1 - +1,5	1/2" unten/below	8114 013010	
-----------	------------------	-------------	--

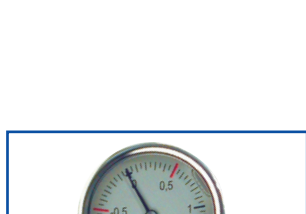

Glyzerin-Vakuu-Manometer

rote Marke bei -0,5 und +0,5 bar

Gehäuse-Ø: 63 mm

Glycerine vacuum manometer

red marking at -0,5 and +0,5 bar

housing-Ø: 63 mm

-1 - +1,5	1/4" unten/below	8113 006005	
-----------	------------------	-------------	--



rote Marke bei -0,5 und +1,0 bar

Gehäuse-Ø: 63 mm

red marking at -0,5 and +1,0 bar

housing-Ø: 63 mm

-1 - +1,5	1/4" unten/below	8113 006010	
-1 - +1,5	1/4" 9 Uhr/9 o'clock	8111 006010	



8

Italian / Bazzoli-Siegerperle system

Italienisches- / Bazzoli-Siegerperle-System

Female coupling for weld on

MT-Kupplung zum Anschweißen

NW	Innen A inside A	außen outside	B
80	70	74	110
100	89	94	132
120	112	118	151
150	139	146	180
200	197	205	245
150 Bazzoli	139	144	188

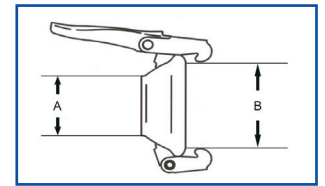

Ball for weld on

Kugel zum Anschweißen

80	70	74	111
100	89	94	130
120	112	118	150
150	139	146	180
200	197	205	243
150 Bazzoli	139	144	186

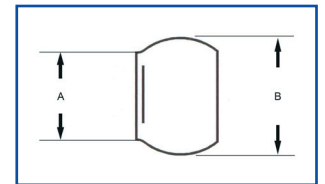

Ring for ball

Ring für Kugel

80	96	-	136
100	89	-	165
120	112	-	185
150	139	-	225
200	197	-	290
150 Bazzoli	176	-	233

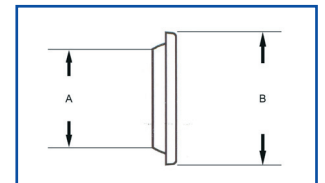

O-Ring

O-Ring

80	-	125	11
100	-	148	12
120	-	170	15
150	-	205	15
200	-	270	18
150 Bazzoli	-	212	15

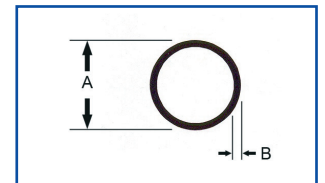

Index Vakuumpumpen

Index Vacuum pumps



Vakuumpumpe Typ PN

Vacuum pumps type PN

Seite/Page 296 - 298



Drehkolbenpumpen

Rotary piston pumps

Seite/Page 305



Schalldämpfer - Zubehör

Muffler - accessories

Seite/Page 299



Statoren für Excenterpumpen

Stators for exentric pumps

Seite/Page 306



Vakuumpumpe Typ PNE-PNR

Vacuum pumps type PNE-PNR

Seite/Page 300 - 304



Lamellen für Vakuumpumpen

Rotor blades for vacuum pumps

Seite/Page 307 - 308